

FREESTYLE DISPLAY UNIT - INSTALLATION GUIDELINES (Parts & Accessories)

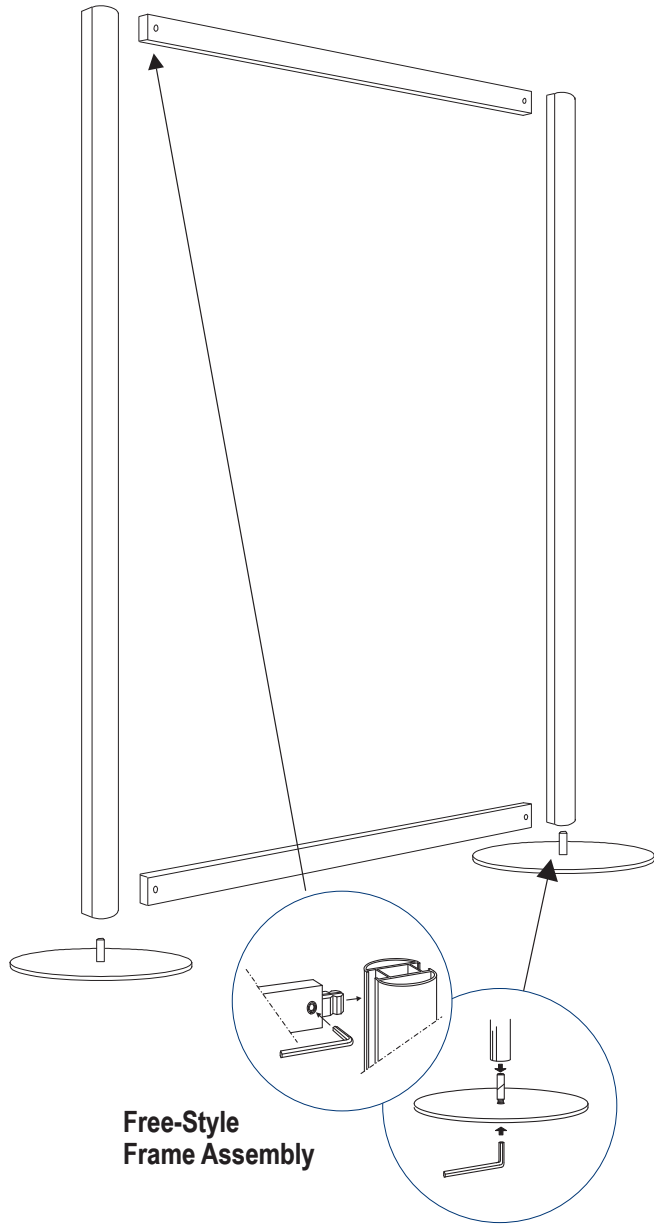

**Free-Style
Frame Assembly**

1.

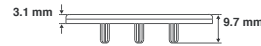

End Cap
Ref. 388

Plastic End Cap
For Use With: TR Series
Colors: Gray

Weight: 0.01lbs

2.

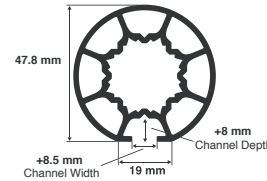

TR 1100
Ref. 133

Lengths: 78"
Compatibility: PH1005 Horizontal Extr.
Finish: Clear anodized

Weight: 5.7 lbs

3.

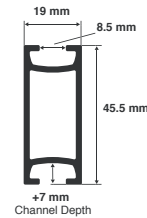

PH 1005
Ref. 104

Lengths: 24" - 42"
Finish: Clear anodized

4.

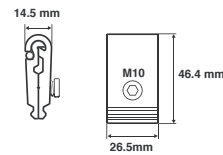

CBX 42
Ref. 324 01

CBX 42 with Screw
For Use With: PH 1005

Hex Key: 5 mm Weight: 0.08lbs

5.

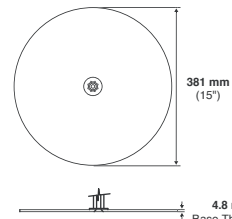

Round Floor Base
Ref. 625 ROUND

Round Floor Base
Material: Steel, black epoxy powder paint
Compatibility: TR Series

Includes: DIN7991 M10 x 30*

Hex Key: 6 mm Weight: 12.8 - 13.5 lbs

CABLE ASSEMBLY

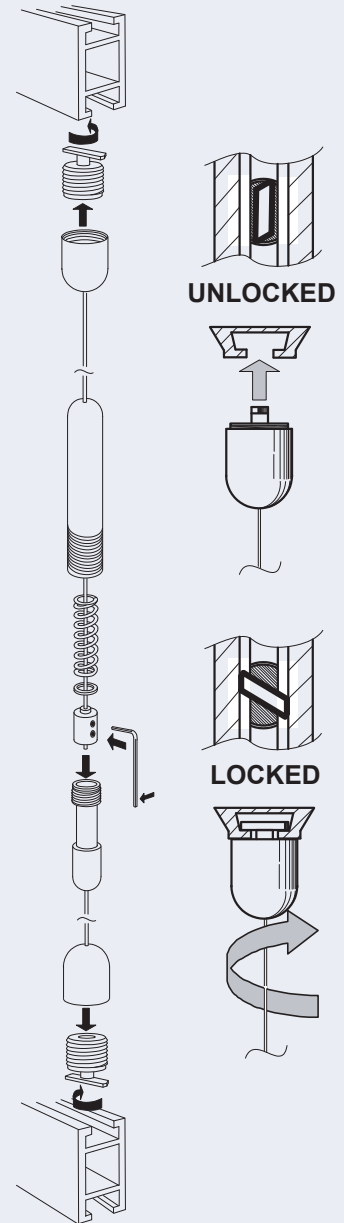

UNLOCKED

LOCKED

DRAWN BY	IV	TITLE	FreeStyle Display Unit	
DATE	06/16/05	SCALE	NTS	TYPE
			Installation Instructions	DRWG REF.
				Freestands- PDF